

# GoWISEUSA®

## ELECTRIC AIR FRYER USER MANUAL

Model No.: GW22958, GW22959



Please read through this manual carefully before use

 **IMPORTANT SAFEGUARDS AND TIPS**

[WWW.GOWISEUSA.COM](http://WWW.GOWISEUSA.COM)

# THANK YOU FOR YOUR PURCHASE!

---

## Join

the GoWISE Community on Facebook, Instagram, Twitter, and Pinterest for updates, tips, and great deals!



## Explore

recipes on our recipe App or [www.gowiseproducts.com/blogs/recipes](http://www.gowiseproducts.com/blogs/recipes)



## Contact Our Customer Care Team

855-233-9199

[support@gowiseusa.com](mailto:support@gowiseusa.com)

Live Chat at [gowiseusa.com](http://gowiseusa.com)

**M-F** 8:30am - 4:00pm MST



## Register Your Product

[www.gowiseproducts.com/apps/product-registration](http://www.gowiseproducts.com/apps/product-registration)

(Normally the serial number is on the bottom of the product. Please check there first.)



## Specifications

Voltage: 120V, 60Hz

Watts: 1400W

Capacity: 5 Qt

Temp. Range: 170°F-400°F



# TABLE OF CONTENTS

---

<b>Register Your Product</b> .....	<b>2</b>
<b>Specifications</b> .....	<b>2</b>
<b>Important Safeguards</b> .....	<b>4</b>
Electromagnetic Fields (EMF).....	5
<b>Product Structure</b> .....	<b>6</b>
<b>Control Display</b> .....	<b>7</b>
<b>Set Up and Using Air Fryer</b> .....	<b>8</b>
Before First Use.....	8
Using Your Air Fryer.....	8
<b>Cooking Guide</b> .....	<b>10</b>
Cooking Chart.....	10
Internal Temperature Chart.....	11
Tips.....	11
<b>Cleaning Your Air Fryer</b> .....	<b>12</b>
<b>Troubleshooting</b> .....	<b>13</b>
<b>Warranty</b> .....	<b>14</b>

# IMPORTANT SAFEGUARDS

---

## HOUSEHOLD USE ONLY • READ ALL INSTRUCTIONS BEFORE USE

- 1. READ THE ENTIRE MANUAL BEFORE ATTEMPTING TO OPERATE.**
2. Keep the box and packing material for storage.
- 3. DO NOT PLACE** the appliance on stove top surfaces.
4. This appliance has a polarized plug (one prong is wider than the other). This plug is intended to fit into a polarized outlet only one way. **TO AVOID ELECTRIC SHOCK, DO NOT** force the plug into the outlet if it does not fit. If the plug does not fit fully into the outlet, reverse the plug. If it still does not fit, contact a qualified electrician. **DO NOT ATTEMPT** to modify the plug in any way.
- 5. DO NOT** immerse the power cord, plug, or any part of the appliance in water or any other liquids to avoid electric shock.
- 6. DO NOT** use the appliance if the plug, the power cord, or the appliance itself is damaged in any way.
- 7. ALWAYS** keep the power cord away from hot surfaces.
- 8. DO NOT** go to any unauthorized person to replace or fix the appliance.
- 9. DO NOT** plug the appliance or operate the appliance with wet hands.
- 10. DO NOT** connect the appliance to an external timer switch or separate remote control system.
- 11. DO NOT PLACE** the appliance against a wall or any other appliances. Leave at least five inches of free space along the back, sides, and above the appliance.
- 12. DO NOT PLACE** anything on top of the appliance.
- 13. DO NOT PLACE** the appliance on or near combustible materials, such as a tablecloth or curtain.
- 14. DO NOT USE** the **GoWISE USA Air Fryer** for any purpose other than described in this manual.
- 15. NEVER OPERATE** the appliance unattended.
- 16.** This appliance is **NOT INTENDED FOR USE** by persons with reduced physical, sensory, or mental capabilities or persons with a lack of experience and knowledge unless they are **UNDER THE SUPERVISION** of a responsible person or have been given proper instruction to use the appliance. This appliance is **NOT INTENDED FOR USE** by children. Make sure that the appliance is out of reach of children, especially when it is operating.
- 17.** Keep all the ingredients in the basket to prevent any contact from heating elements. **DO NOT OVERFILL** the basket.
- 18. DO NOT** fill the basket with oil. Filling the basket with oil is a fire hazard.

# IMPORTANT SAFEGUARDS

## HOUSEHOLD USE ONLY • READ ALL INSTRUCTIONS BEFORE USE

### 19. DO NOT COVER OR BLOCK

the air inlet and outlet while the appliance is in operation. Doing so prevents even cooking and may damage the unit or cause it to overheat.

### 20. DO NOT touch the inside of the appliance while it is operating.

21. During hot air frying, hot steam is released through the air outlet openings. Keep your hands and face at a safe distance from the steam and from the air outlet opening. **BE CAREFUL** of hot steam and air when you remove the basket from the appliance. Any accessible surface may become hot during use.

22. **IMMEDIATELY UNPLUG** the appliance if you see dark smoke coming out from the appliance. Wait for the smoke emission to stop before you remove the basket from the appliance.

23. **ENSURE** that the appliance is placed and operated on a horizontal, even, stable, and noncombustible surface.

24. This appliance is designed for **HOUSEHOLD USE ONLY**. It is not safe to use in environments, such as staff kitchens, farms, motels, and other non-residential environments.

25. If the **GoWISE USA Air Fryer** is used improperly, for professional or semi-professional purposes, or if it is not used according to the instructions in this user manual, the warranty becomes invalid,

and the manufacturer will not be held liable for damages.

26. **ALWAYS** unplug the appliance after use.

27. **ALWAYS** wait 30 minutes for the appliance to cool down before handling, cleaning, or storing.

28. The base of the **GoWISE USA Air Fryer** vents heat during the cooking process. Artificial stone countertops are not heat resistant. It is the end-user's responsibility to verify the heat capacity of their countertops. We recommend using a silicone pad or spare, non-artificial tile to protect your counters from heat damage. **The care and use of countertops is the responsibility of the end user.**

29. Over time, wear and tear is normal for the basket and crisper tray and will need to be replaced from time to time. Please contact GoWISE Customer Care or visit our website [gowiseproducts.com](http://gowiseproducts.com) to purchase these parts.

### Electromagnetic Fields (EMF)

This appliance complies with all standards regarding Electromagnetic Fields (EMF). Under proper handling, the appliance is safe to use based on available scientific evidence.

**SAVE THESE  
INSTRUCTIONS**

# PRODUCT STRUCTURE

## PARTS

1. Air Inlet
2. Display Screen
3. Control Panel
4. Fry Basket
5. Handle
6. Crisper Tray
7. Basket Divider

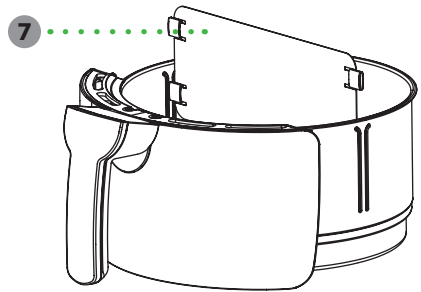
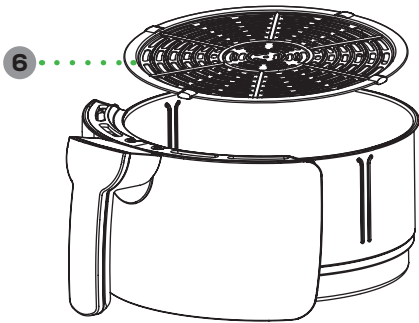
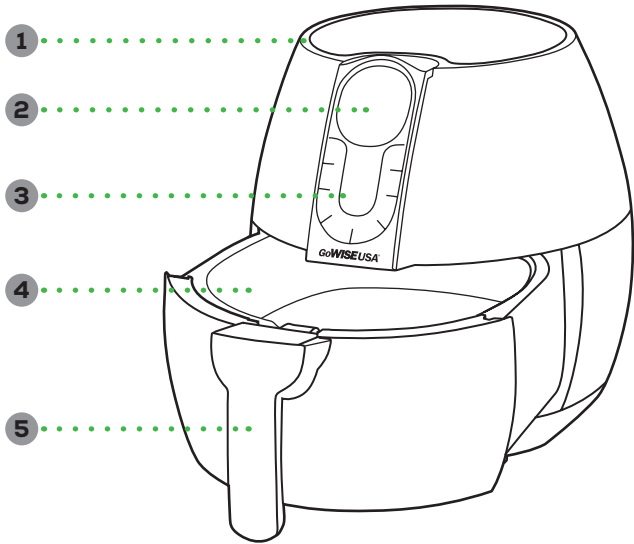

# CONTROL DISPLAY

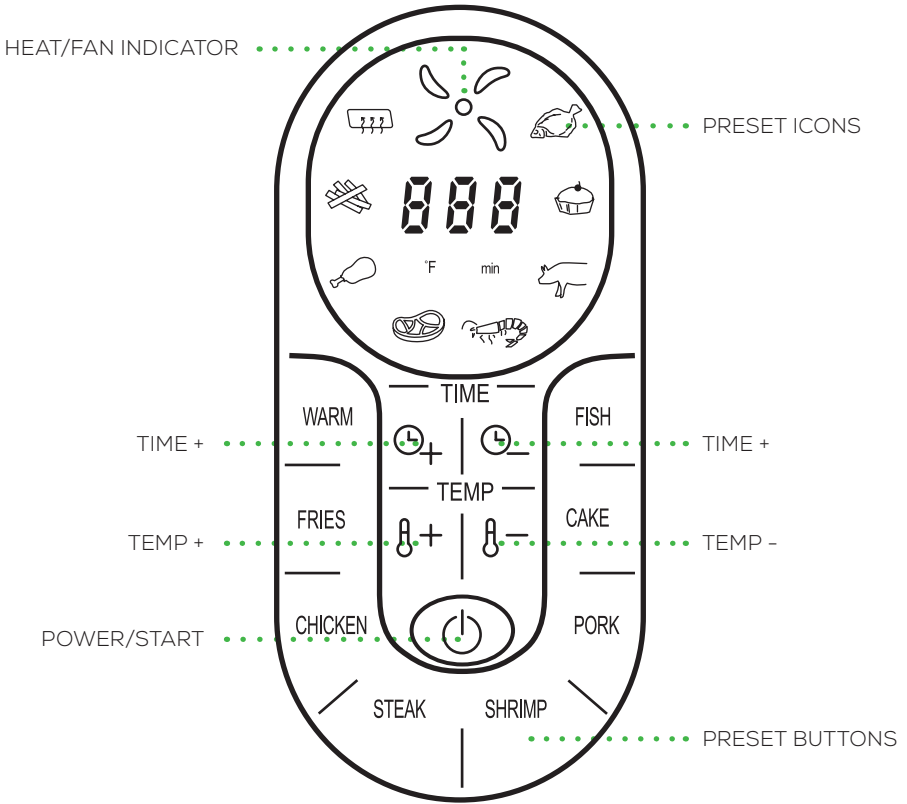

## BUTTONS

**POWER/START:** Powers the unit on and off; starts the cooking process

**TIME + & - :** Increase or decrease cooking time

**TEMP + & - :** Increase or decrease cooking temperature

## PRESET BUTTONS

**Warm :** 5 minutes at 370°F

**Fries :** 20 minutes at 400°F

**Chicken :** 20 minutes at 380°F

**Steak :** 25 minutes at 390°F

**Fish :** 20 minutes at 370°F

**Cake :** 25 minutes at 350°F

**Pork:** 15 minutes at 370°F

**Shrimp :** 15 minutes at 330°F

# SET UP AND USING AIR FRYER

---

## BEFORE FIRST USE

1. Remove all packaging materials, stickers, and labels.
2. Clean the basket, crisper tray, and basket divider with hot water, soap, and a non-abrasive sponge.
3. Wipe the inside and outside of the appliance with a clean cloth.
4. Set the unit to 350°F for about 5 minutes. This process will burn off any remaining residue left from the manufacturer. There may be a slight burning smell which will dissipate after a few minutes.
5. Your new GoWISE USA Air Fryer is now ready for use!

**NOTE: DO NOT** fill the basket with oil or lard. The appliance uses rapid air circulation to fry.

## USING YOUR AIR FRYER

1. Place the air fryer on a flat and even surface. **DO NOT PLACE THE AIR FRYER ON A SURFACE THAT IS NOT HEAT RESISTANT.**
2. Place the crisper tray in the basket. **DO NOT FILL THE BASKET WITH OIL OR ANY OTHER LIQUID.**
3. Place the ingredients in the basket and then slide the basket back into the appliance.
4. Press the POWER/START button and set cooking time and temperature by either choosing one of the 8 presets or manually setting time and temperature with “+” or “-” buttons.
5. Once you have set the cooking time and temperature, press the POWER/START button again. The HEAT/FAN icon will blink to show that the fryer is heating up and circulating hot air.
6. You may need to shake the ingredients midway through the cooking cycle. Pull the basket out of the air fryer by the handle, and carefully shake the ingredients inside the basket.

**NOTE:** The air fryer will automatically power down when you pull the basket out, but your cooking settings will remain.

**CAUTION:** If you are cooking heavy ingredients, we recommend holding the bottom of the basket with an oven mitt for extra support.



# SET UP AND USING AIR FRYER

## USING YOUR AIR FRYER

- Slide the basket back into the air fryer by carefully aligning the track inside the air fryer with the rim of the basket. If you are unable to insert the basket into the air fryer, try lifting the handle as you are sliding the basket into the fryer.
- When the cooking time has been reached, the timer will beep five times. After the timer beeps, the fan will stop shortly after (approx. 20 seconds).
- Slide the basket out of the fryer and place it on a pot holder.  
**NOTE:** Oil from the ingredients will gather in the bottom of the basket. Be careful when sliding the basket out of the fryer.
- To remove the ingredients, carefully pour ingredients out of the basket onto a plate.  
**NOTE:** We recommend using silicone tipped tongs to remove ingredients from the basket especially if ingredients are greasy.
- Press the POWER/START button and the fan will run for approximately 20 seconds, then will go into standby mode.  
**NOTE:** You must unplug the fryer to turn it off completely.

### Basket Divider

Use the basket divider to cook 2 different foods at one time.

**How to use:** Install the basket divider into the grooves of the fry basket. Add the ingredients into the sides of the divider.

**NOTE:** It is recommended to cook food with similar cooking times and temperature settings.

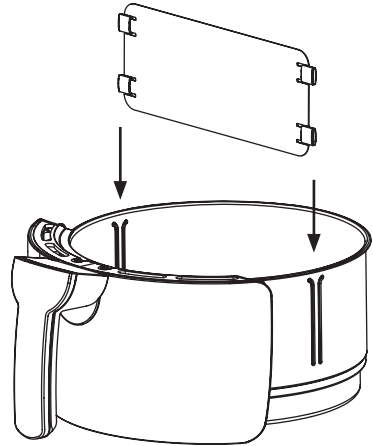

To order replacement parts please contact our Customer Care Team.

855-233-9199

support@gowiseusa.com

Live Chat at gowiseusa.com

**M-F** 8:30am - 4:00pm MST

# COOKING GUIDE

The chart here is a guide that will help you with setting the time and temperature for certain ingredients.

Food	Time	Temperature	Shake/Flip	Tips
<b>Potatoes &amp; Fries</b>				
Thin Frozen Fries	9-16 min	400°F	Shake	Add 1/2 Tbsp of Oil
Thick Frozen Fries	11-20 min	400°F	Shake	
Homemade Fries	16-20 min	400°F	Shake	
Homemade Potato Wedges	18-22 min	360°F	Shake	
Homemade Potato Cubes	12-18 min	360°F	Shake	
Falafel	15 min	360°F	Shake	
Potato Gratin	15-18 min	400°F	/	
<b>Meat &amp; Poultry</b>				
Steak	8-12 min	360°F	Flip	Line with tin foil
Pork Chops	10-14 min	360°F	Flip	
Hamburger	7-14 min	360°F	Flip	
Sausage Roll	13-15 min	400°F	Flip	
Drumsticks	18-22 min	360°F	Flip	
Chicken Breast	10-15 min	360°F	Flip	
<b>Snacks</b>				
Spring Rolls	8-10 min	400°F	Shake	/
Frozen Chicken Nuggets	6-10 min	400°F	Shake	
Frozen Fish Sticks	6-10 min	400°F	Shake	
Frozen Mozzarella Sticks	8-10 min	360°F	Shake	
Stuffed Vegetables	10 min	320°F	/	
<b>Baking</b>				
Cake	20-25 min	320°F	/	Use baking pan (not included)
Quiche	20-22 min	360°F	/	
Muffins	15-18 min	400°F	/	
Sweet Snacks	20 min	320°F	/	

# COOKING GUIDE

## INTERNAL TEMPERATURE CHART

\*This chart should be used to check the temperature of cooked meats. Always review USDA Food Safety Standards.

Food	Type	Internal Temperature
Beef + Veal	Ground	160°F (70°C)
	Steaks, Roasts: medium	160°F (70°C)
	Steaks, Roasts: rare	145°F (63°C)
Chicken + Turkey	Breasts	165°F (75°C)
	Ground, Stuffed	165°F (75°C)
	Whole bird, legs, thighs, wings	165°F (75°C)
Fish + Shellfish	Any type	145°F (63°C)
Lamb	Ground	160°F (70°C)
	Steaks, Roasts: medium	160°F (70°C)
	Steaks, Roast: rare	145°F (63°C)
Pork	Chops, Ground, Ribs, Roasts	160°F (70°C)
	Fully cooked Ham	140°F (60°C)

### NOTES:

- Please keep in mind that because ingredients differ in size, shape, brand, and origin, we cannot guarantee that this is the best setting for the ingredients you have.
- Rapid Air Technology reheats the air inside the fryer instantly; therefore, removing the basket of the air fryer for a brief period of time will not interrupt the cooking process.

### TIPS

- Small ingredients usually require shorter cooking time compared to larger ingredients.
- Shaking smaller ingredients midway through the cooking

process will ensure the ingredients cook more evenly and give a better end result.

- Adding a very little amount of oil to fresh potatoes will give it a crispier result.
- Do not prepare extremely oily ingredients in the air fryer.
- Snacks that can be prepared in a traditional oven can also be prepared in the air fryer.
- The recommended amount of fries to allow for a crispy result is 17.5 oz.
- Pre-made dough requires shorter cooking time than home-made dough.
- When making cake, quiche or ingredients with filling, use a baking tin or oven dish in the fryer basket.

# CLEANING YOUR AIR FRYER

---

- 1.** Clean the fryer after every use. Unplug the fryer. **ALWAYS WAIT UNTIL THE FRYER HAS COOLED TO A SAFE TEMPERATURE BEFORE HANDLING.**
- 2.** Wipe the outside of the fryer with a damp cloth.
- 3.** Wash the basket, crisper tray, and basket divider with hot water, soap and a non-abrasive sponge. You can remove any stuck-on food by using a degreasing liquid soap. For any hard-to-remove food, soak the basket and crisper tray in hot water.
- 4.** Clean the inside of the appliance with a lightly dampened non-abrasive sponge or cloth. Be careful not to get the inside of the appliance too wet and never submerge in water.
- 5.** Scrub the heating element with a cleaning brush to remove any food debris.

# TROUBLESHOOTING

Problem	Possible Cause	Solution
The fryer is not turning on	The appliance is not plugged in	Plug the appliance into a grounded wall socket.
	You have not set the timer	Set the timer using the control display to the correct time on the appliance.
Ingredients for the fryer are not done	The basket has been overfilled with ingredients	Place smaller batches of ingredients in the basket. Smaller batches are fried more evenly.
	The set temperature is too low	Increase the temp. to the required temperature setting (see pg. 10).
The ingredients are fried unevenly in the fryer	Ingredients positioning or overflow	Ingredients that lay on top or across from each other (e.g. fries) need to be shaken midway through cooking.
Fried snacks are not crispy after frying	Some snacks are crispier when traditionally fried	Use oven snacks or lightly brush some oil onto the snacks for a crispier result.
Basket does not slide into the fryer properly	Overfilled basket	Do not fill the basket beyond the MAX fill indicator line.
White smoke comes out from the fryer	It is normal for white smoke to appear when prepping greasy ingredients	When frying greasy ingredients, a large amount of oil will leak into the basket. The oil produces white smoke and the basket may heat up more than usual. This does not affect the appliance or end food result.
	The basket is still greasy	Clean the air fryer properly after each use.
Fresh fries are fried unevenly in the fryer	Potatoes are not fresh	Use fresh potatoes and place them in the freezer for 30 minutes before air frying to help them stay firm during frying.
	Potato sticks have not been rinsed properly prior to frying	Make sure to rinse the potato sticks properly to remove the starch prior to frying.
Fries are not crispy	Oil and water in the fries	Potato sticks should be dry prior to adding oil.
		Add more oil for a crispier result.

If your **GoWISE USA Air Fryer** displays any error codes, please contact our Customer Care Team.

855-233-9199

support@gowiseusa.com

Live Chat at gowiseusa.com

**M-F** 8:30am - 4:00pm MST

# WARRANTY

---

GoWISE USA warrants all products against defects in materials and workmanship for **one (1) year** effective from the date of purchase.

GoWISE USA will replace any products that are found to be defective due to manufacturer flaws based on eligibility. Refunds issued by GoWISE USA must be purchased directly from GoWISE USA and are only available to the original purchaser within the first 30 days. We do not issue refunds for items bought by thirdparty retailers.

This warranty extends only to personal use and does not extend to products that has been used for commercial, rental or any other use this product was not intended for. There are no warranties other than the warranties expressly set forth with each product.

This warranty is non-transferrable. GoWISE USA is not responsible in any way for any damages, losses, or inconveniences caused by equipment failure by user negligence, abuse, or use noncompliant with the user manual or any additional safety, use, or warnings included in the product packaging and manual.

This warranty only covers purchases within the 48 contiguous states of United States of America. For purchases made outside the 48 contiguous states, such as AK, HI, PR, or Canada, we will replace the unit under the one-year warranty upon receipt of a proven defect by video or picture. However, the replacement will only ship to a freight forwarder or address within the 48 contiguous United States. The consumer is responsible for arranging shipment outside of the 48 contiguous states.

GoWISE USA assumes no liability for damage caused using this product other than for its intended use or as instructed in the user manual. Some states do not allow this exclusion or limitation of incidental or consequential losses, so the foregoing disclaimer may not apply to you. This warranty gives you specific legal rights and you may also have other rights which may vary from state to state.

ALL EXPRESSED AND IMPLIED WARRANTIES INCLUDING THE WARRANTY OF MERCHANTABILITY, ARE LIMITED TO THE PERIOD OF THE LIMITED WARRANTY.

**NOTE:** General Warranty excludes refurbished / auction items.

# WARRANTY

---

## Additional 60-Days Warranty

You can extend your 1-year warranty by an additional 60 days. Log onto [www.gowiseproducts.com/apps/ product-registration](http://www.gowiseproducts.com/apps/product-registration) and register your product within the first 14 days of your purchase for the extended warranty.

## DEFECTIVE PRODUCTS & RETURNS

If your product is defective within the 1-year warranty period, please email our Customer Care Team at [support@gowiseusa.com](mailto:support@gowiseusa.com). To expedite your issue, please provide the 4 items below:

1. Copy of the invoice, order information, or gift receipt showing the date of purchase
2. Serial number, usually found on a sticker located on the bottom on back of the unit
3. Picture or video of the issue or defect that you are experiencing
4. Shipping address information

## Authorized Retailers:

Amazon

GoWISE USA

WayFair

Houzz

Home Depot

etailz

MorningSave.com

Bed Bath & Beyond

Jet.com

Walmart.com

Macy's

**GoWISEUSA®**

WWW.GOWISEUSA.COM

855-233-9199

support@gowiseusa.com

Live Chat at gowiseusa.com

**M-F** 8:30am - 4:00pm MST

- To ensure the correct use of this appliance, read these instructions carefully and thoroughly.
- Please keep this manual for future reference.
- Thank you for purchasing this GoWISE USA Electric Air Fryer.

USE PROMO CODE: **LIVewiseraF**

**10% OFF**

YOUR NEXT **GoWISEUSA®** PURCHASE

